

Space Solar Power Systems of Gyroscopic and Cyclic Functioning with Element Compatibility of Components and New Algorithm of Conversion of Thermal Radiation

Yu.M. Mar'yinskykh

**Gyroscopic Solar Power Satellite with the New Thermal Conversion System and Superconductive
Generator**

DOI: 10.3103/S0003701X19060070

New Generation Thermodynamic Autonomously Managed Space Solar Power Plant

DOI:10.1134/S1810232814040109

The Material of the Working Fluid of the Solar Energy Heat Converter for Space Application

DOI: 10.2412/mmse.90.3.605



Problems in the Development and Implementation of SPS Projects

The scientific and practical significance of the developed projects of space solar power systems of gyroscopic and cyclic functioning should be presented in the context of a brief acquaintance with the previously developed companies "Boeing", "Rockwell Int" under the NASA program with the participation of the Nobel Prize laureate physicist P. Glazer.

The main problem in the development of projects for space solar power plants (SSPS) was the choice of thermal or photovoltaic conversion system.

Despite all the advantages: the high efficiency of the thermal conversion system (up to 39%), the technology for the production of turbine generators with a developed industrial base has been mastered, the use of not scarce materials that are resistant to the effects of space radiation, there are factors that hinder the implementation of these projects. These include the large specific gravity of the conversion system on average equal to $3.4 \text{ kg}\cdot\text{kW}^{-1}$ [1], Solar Power Satellite (SPS) (see Table).

Elements	Weight, T
Heat dissipation system	10769
Basic structure	6254
Working body (potassium)	6085
PTP with electric generators (1.15 GW)	1933
Facets	1837
Radiation receivers	1000
Secondary capacitors	324
Total:	48175

The designers of the SPS (the author's assumption) relied on a strategy for the future development of the space industry, in which the launch vehicles are capable of launching payloads with the required weight and size characteristics into geostationary orbit. So projects with gas turbine conversion systems, designed to obtain 10 GW of electrical power at the output electric buses of the ground receiving rectenna, were subjected to changes in the subject of thermal systems [3,4]. As a result, a need arose for a guidance system to keep the reflected radiation above the entrance to the receiver opening. A guidance system was developed.

This system is not a solution to the guidance problem, since during the operation of the SPS, mechanical vibrations will occur that are as close to resonating as possible, which leads to zero the expected effect. Mechanical vibrations will be transmitted through the conversion system and can lead to the likelihood of destruction of individual resonate units and parts of the SPS. This problem is not considered in projects.



Direct photovoltaic conversion system has several advantages on deploying flexible photoconverting panels with relatively low mass parameters in space . Today it is a priority and partially started to be implemented by the leading space countries.

However, it is difficult to calculate the cost of producing the required amount of photoconverting material and working elements from it. There is no unambiguity in the cost of one kilowatt of electricity generated by the orbital SPS taking into account the resource of solar cells in space. These factors, as well as the problems of implementation of projects of thermal solar power plants, give grounds to reconsider the traditional methods of converting thermal solar energy into a solar power plant.



At the present stage, the possibility - of using super-strong and lightweight structural materials made of carbon-carbon composites for the manufacture of the frame and load-bearing elements of power systems for space purposes has arisen. The use of high-temperature superconductors and superconducting electric generators created on their basis can significantly reduce the weight and size parameters of the superconducting SPS of the thermal conversion system.

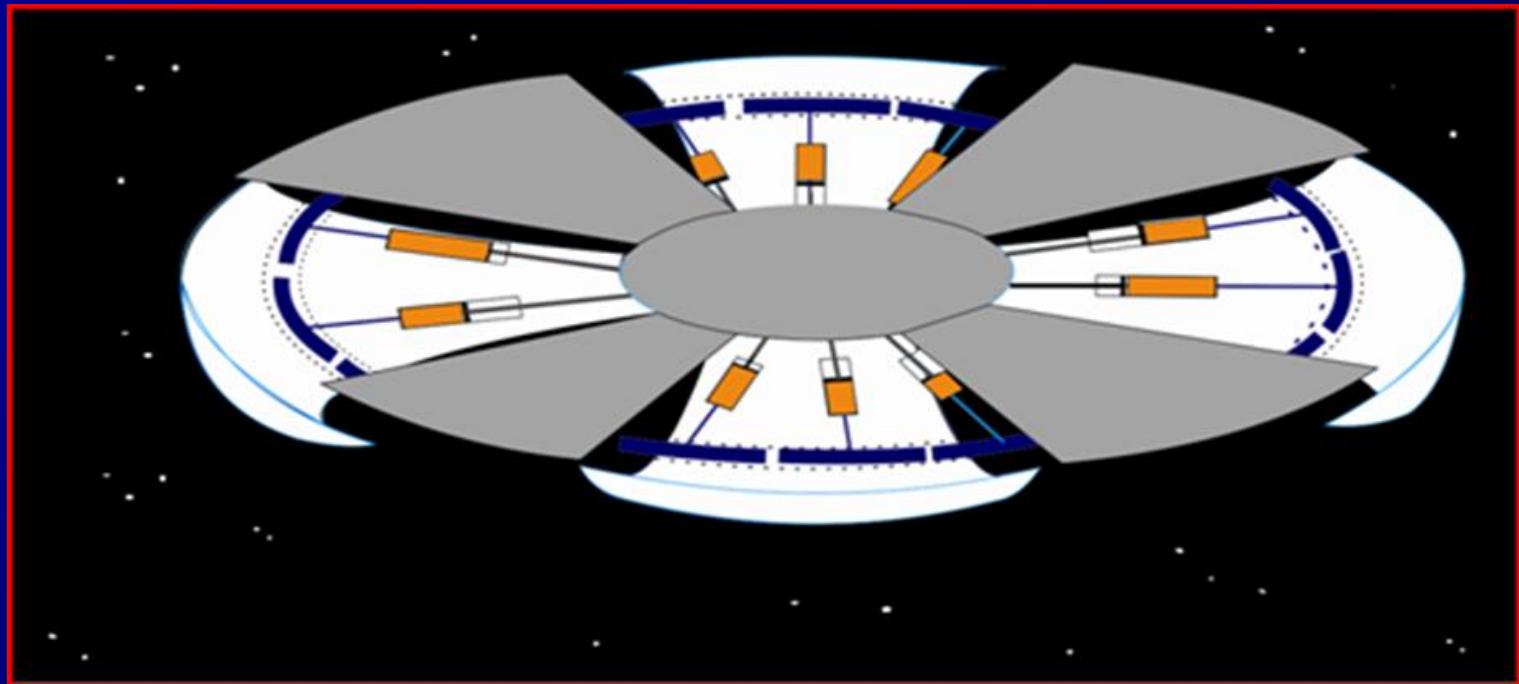

Unique features of a gyroscopic satellite solar power plant (GSPS) with a new thermal conversion system (TCS) and a superconducting generator

Main features of the proposed project is that it has the ability to convert solar energy into mechanical and electrical in the required ratios. The project provides for the possibility of placing and creating a high-tech production at the power plant with controlled artificial gravity.

The features of GKSE should be attributed to low costs when creating relatively cheap components compared to photoconverting GSPS, for which heterostructured (multilayer) flexible CIGS solar cells based on $\text{Cu}(\text{InGa})\text{Se}_2$ are considered suitable. But due to the complexity of the technological process on unique equipment, when they are manufactured by different manufacturers, the cost ultimately turns out to be very high. Large surfaces of such expensive photoconverters cannot be protected from the destructive effects of electrons, protons and meteor showers.

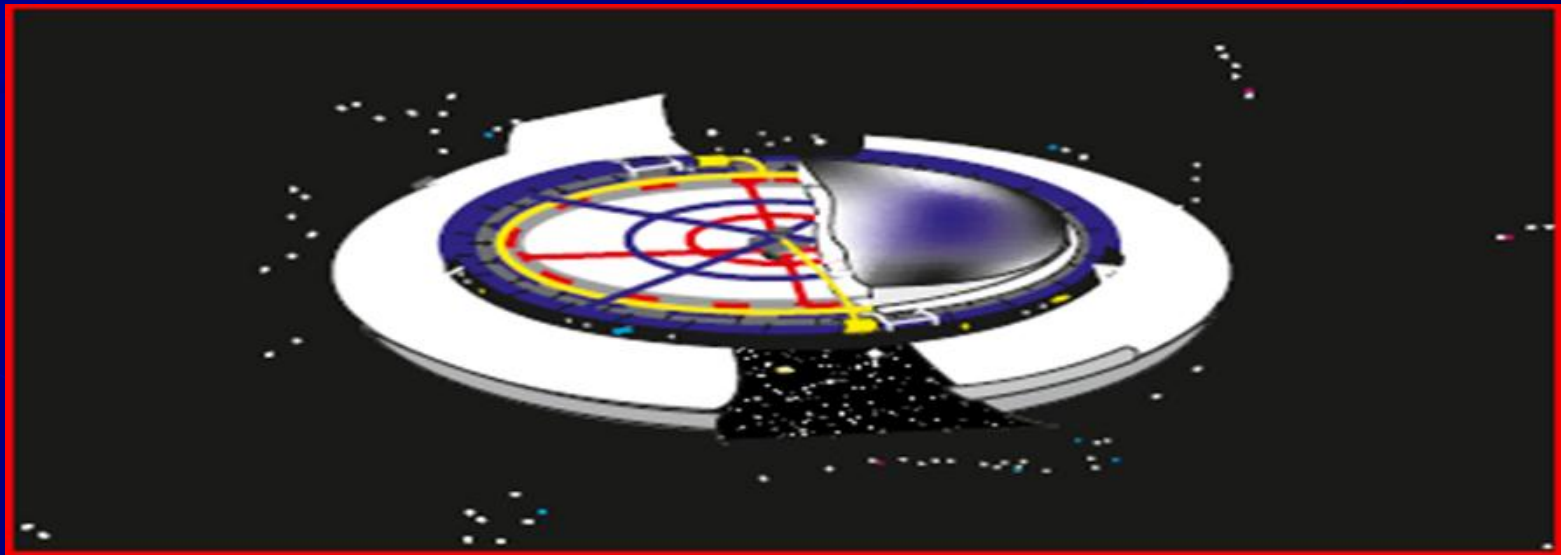

A feature of the created project of a gyroscopic solar power satellite with a new thermal conversion system (TCS) and a superconducting generator is a fundamentally different approach to converting the energy of the full spectrum of solar radiation into mechanical and electrical in the required ratios than had previously been developed in the field of space energy. The construction of the power plant provides for the creation and deployment of high-tech production with controlled gravity.

The design makes it possible not to use steam and gas turbine installations, a guidance system, as well as a radiator refrigerator, the mass of which would be about half of its total mass. Their role is played by heat-converting modules moving in a circular tunnel cavity "heat trap", which has a transparent surface with a low-emission coating. The use of high-temperature superconductors in GSPS, as well as heat-resistant and lightweight structural materials made of carbon-containing composites, significantly improves its energy and weight and dimensions. This can be inexpensive when it is created with relatively cheap components compared to photoconverting SPS. The principle of operation of the power plant realizes the possibility of basing similar converters on celestial objects.

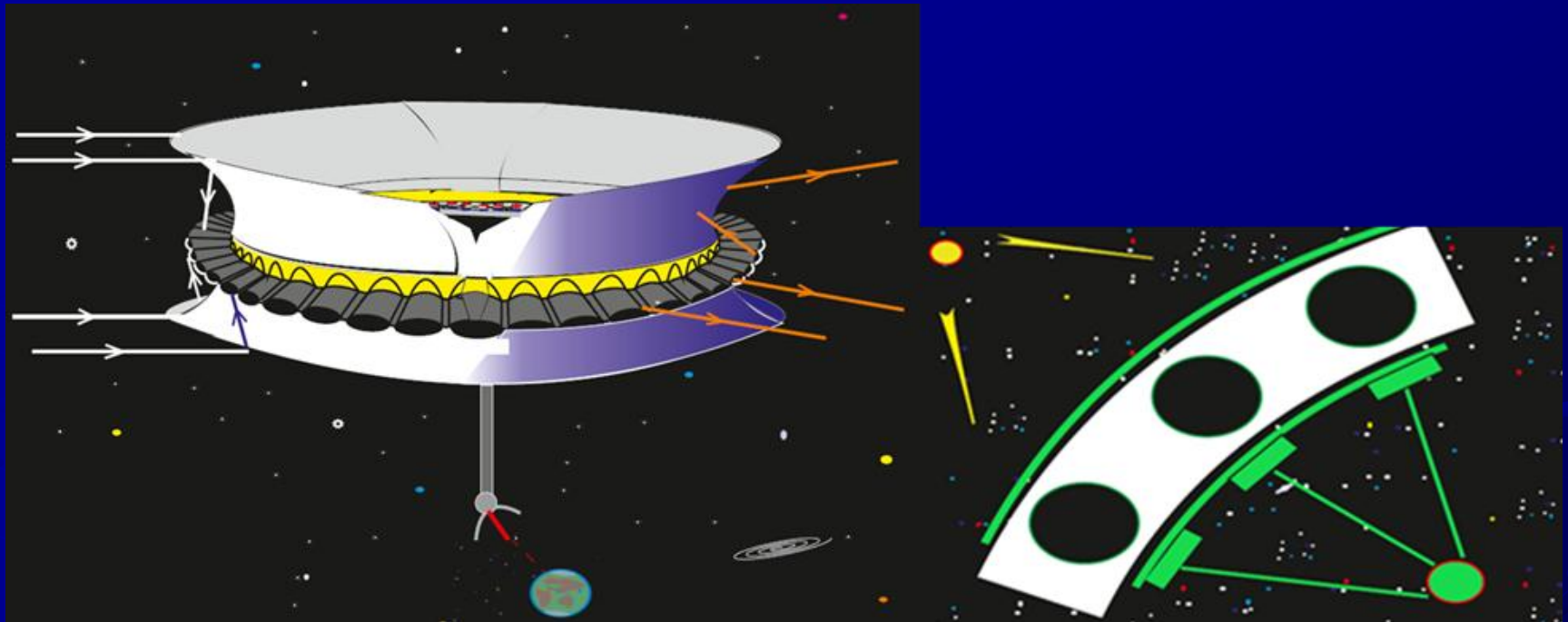

The use of high-temperature superconductors (HTSC) of the 2nd generation in the power plant, the production of which has already been mastered, as well as heat-resistant and lightweight structural materials made of carbon-containing composites [16,17,18,19] significantly improves its energy and weight and dimensions. The combination of a high-temperature heat sink and low-temperature superconducting circuits of the generator located behind the heat shield makes it possible to set the required temperature regime in space during the entire life cycle.

Gyroscopic Space Solar Power Plant with New Thermal Conversion System and Superconducting Generator

DOI: 10.3103/ S0003701X19060070

Abstract . The analysis of methods for converting solar energy in projects of space solar power plants and analyzes the problems hindering their implementation. The efficiency of its operation is explained by its design feature, as well as the use of ultra-strong materials made of carbon composite, a transparent low-emission magnetron coating of a circular tunneling cavity "heat trap" and high-temperature superconductors.

The device and the principle of operation of the power plant are considered in detail. An assessment of the energy and weight and size parameters is given, the calculation of specific indicators during operation is carried out, depending on the degree of solar concentration and the type of the working fluid. The following evaluation results are presented: thermal efficiency of conversion as a working medium of helium at a concentration of solar energy 74 and water vapor at 38 was 85% and 62.7%, respectively; the specific gravity of the entire thermal conversion system was $2.17 \text{ kg} \cdot \text{kW}^{-1}$ and $2.61 \text{ kg} \cdot \text{kW}^{-1}$; its specific power is $12.3 \text{ kW} \cdot \text{m}^{-2}$ and $6.79 \text{ kW} \cdot \text{m}^{-2}$, the specific gravity of the power plant was $0.46 \text{ kW} \cdot \text{kg}^{-1}$ and $0.38 \text{ kW} \cdot \text{kg}^{-1}$. The proposed operating principle can be used at space power plants based on planets and the Moon.

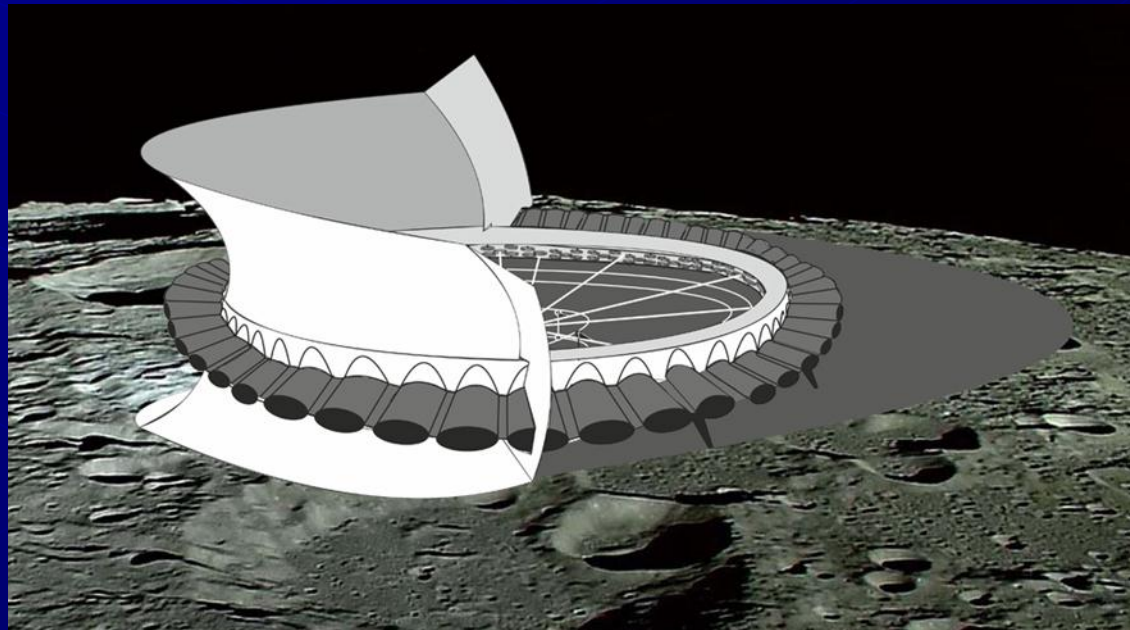



Main Parts of the GSPS Structure

In the designs of the developed projects, the combination of the implementation of functional processes by the same parts of the structure is used to convert the energy of the full spectrum of solar radiation into mechanical and electrical in the required proportions.

The design of the power plant is a single architecture of a technical structure, consisting of 4 parts:

- the first is a circular system of heat-converting modules;
- the second is a superconducting generator, which is a synchronous electric machine;
- the third is a solar concentrator in the form of an incomplete circular paraboloid;
- fourth - hermetic space above the GSPS load-bearing frame with production, technical and service rooms.



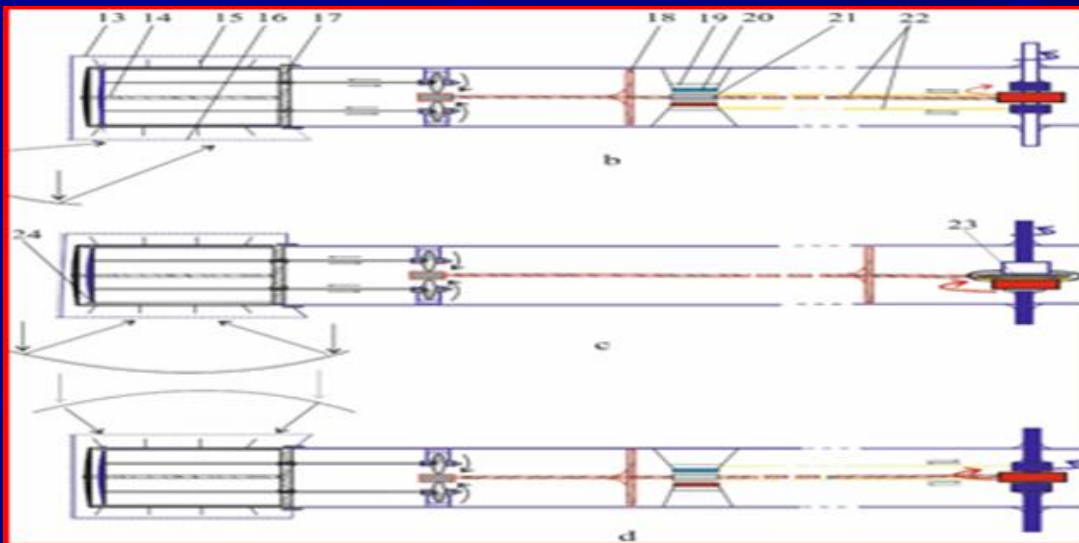
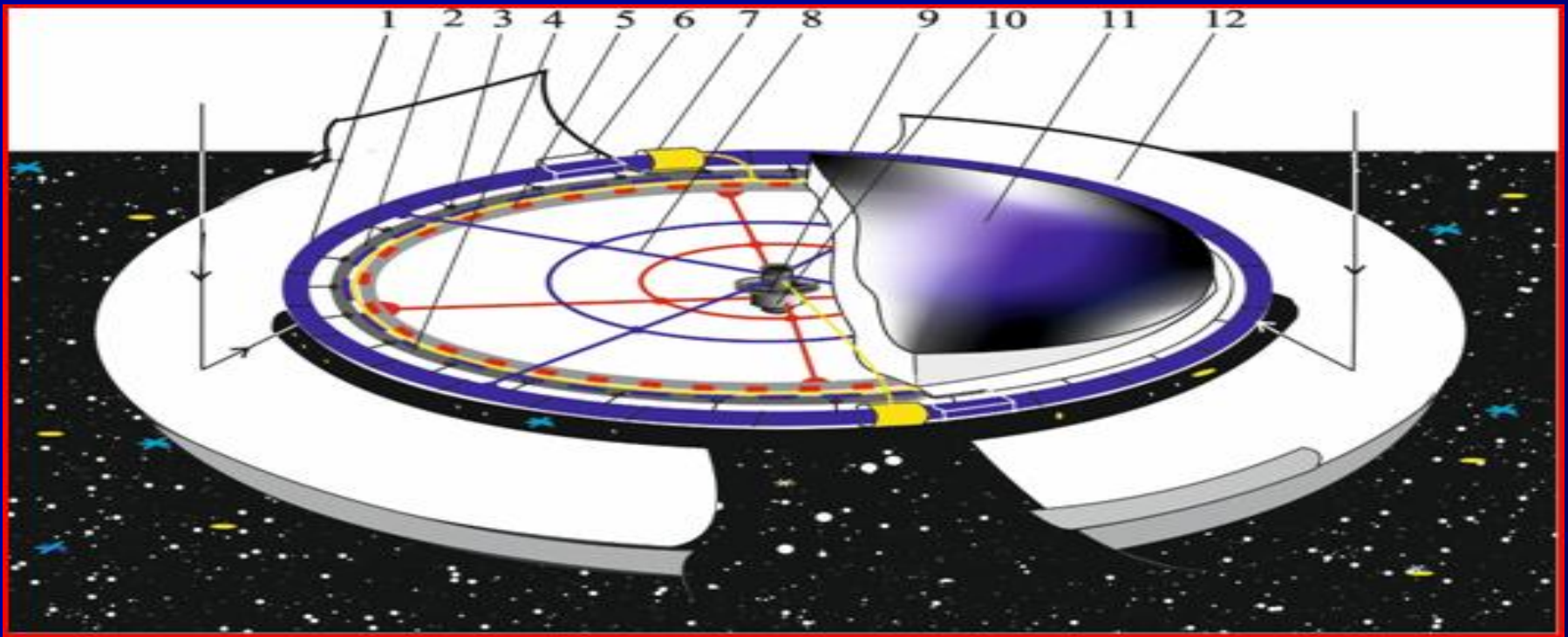

Fig. 2. Schematic diagram of the transformation of the translational movement of the rod into rotational movements of the supporting frames of the power plant

The Second Version of the GSPS Project

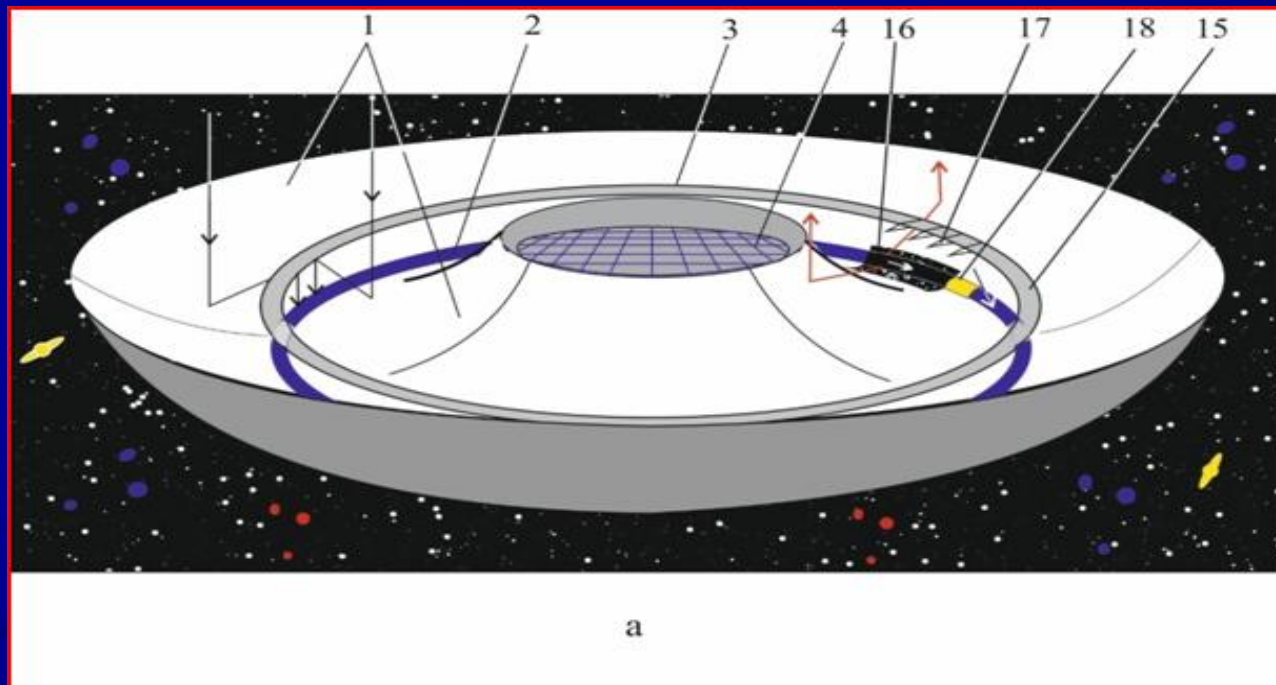

Fig.3. SPS and a composite film concentrator of solar radiation above the heat receiver (a), cross section of the power plant (b)

1- paraboloid concentrator ; 2- circuit of heat-converting modules ; 3 - paraboloid reflector of concentrated solar radiation ; 4 - solar elements ; 5- heat-converting module ; 6 - kinematic connection docking unit ; 7- protective heat shield of the foil ; 8 - stator winding ; 9- technological room ; 10 - cryostat ; 11.12 - shaft of the stator and rotor power frame ; 13- loop circulating refrigerant ; 14 - superconducting rotor coils ; 15 - counter reflector ; 16- modules in the radiant zone (in dependence on the size of the power plant such zones may be several) 17 - reflecting system for concentrated

Cycles of the Heat Converter: Helium as an Actuating Medium (A), Water Steam as an Actuating Medium (B)

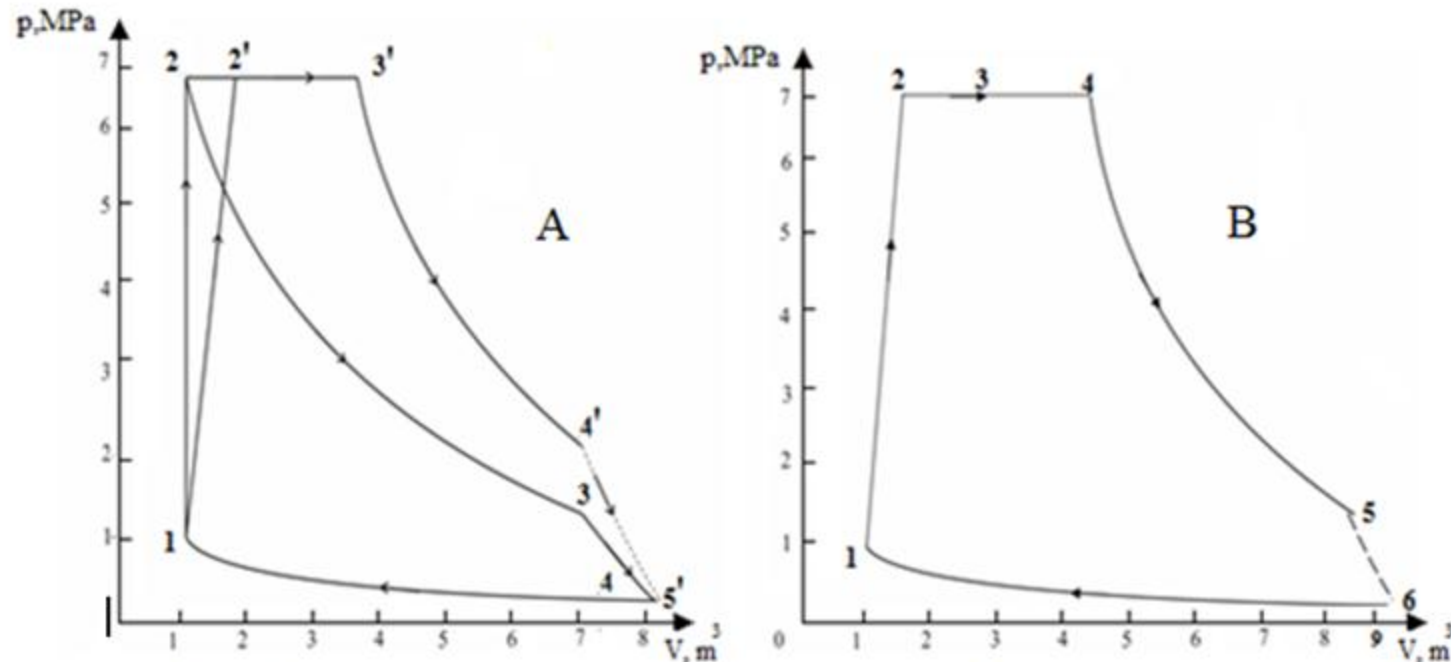

Fig. 4. Thermal converter cycles: working medium helium (A), working medium water vapor (B)

Fig. 4. Cycles of the heat converter: helium as an actuating medium (A), water steam as an actuating medium (B)

1-2'-3'-4'-5' variant of the operating cycle of the heat converter at a high degree of solar concentration, slope 1-2' depends on the ratio of load values and solar concentration (A)

1-2 - heating water to the boiling point at point 2; 2-3 - boiling during the isobaric-isothermal process; 3-4 - steam overheating; 4-5 - intense heat release in the initial section at a higher temperature of the chamber body with the working fluid; 5-6 - completion of steam condensation in the refrigerator; 6-1 - transfer of the piston and condensate to the initial position and state (B)

Comparison of GSPS thermal conversion schemes (with scanning of the thermal heat sink of two variants) and SPS

1. Heat receiver module with working fluid; 2. Frame of a thermal trap; 3. Connecting element of modules; 4. Kinematic transducer of translational motion in rotational; 5. The case of industrial and technical purposes; 6. Photoconverting surface; 7. Superconducting generator; 8. Pump; 9. Refrigerant circuit

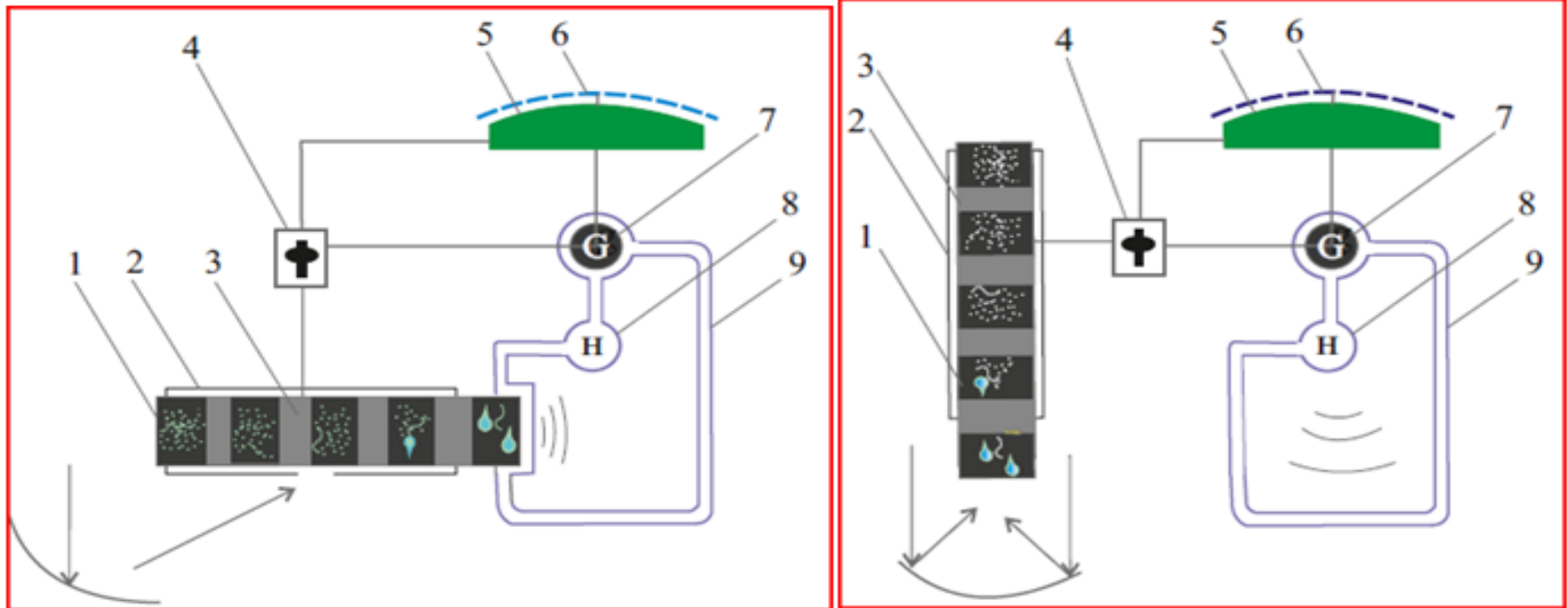

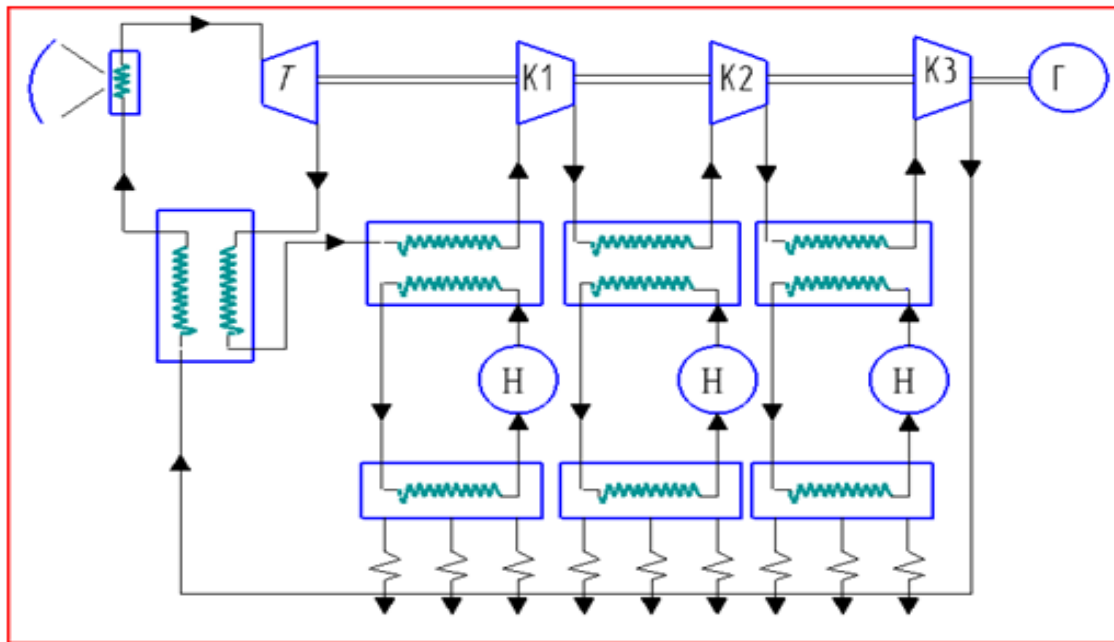

In SPS heat conversion system heat dissipation by weight more than half of the total mass

Energy and Size Indicators of GSPS with New TCS and Superconducting Generator

Table 1. Efficiency of the solar radiation heat converter $W_{t.c.}$, power efficiency of the superconductor generator W_g , and its specific performance based on the solar concentration values

n	30	32	34	36	38	40	42	44	72
Capacity t.c., kW	60	67	73	79.4	85.5	91.5	97.4	103	158
Capacity g., kW	57	63.6	69.4	74.6	82.2	87.8	93.5	99	152
Specific capacity, kW/kg	0.24	0.28	0.3	0.33	0.36	0.38	0.4	0.43	0.66

APPLIED SOLAR ENERGY Vol. 55 No. 6 2019

Table 2. Energy characteristics, weight and dimensions of the GSPS with the new TCS and superconductive generator

Working fluid	Helium	Water steam
Solar concentration	74	38
Power plant solar thermal conversion system diameter, m	150	150
Number and/capacity of all energy modules, MW	205/11.4	145/12.8
Working fluid and/module weight, kg	$\frac{3}{118}$	$\frac{66}{165}$
Max and/min cycle temperature, K	$\frac{1300}{200}$	$\frac{1000}{373}$
Time of cycle, s	276	662
Efficiency of energy conversion by working fluid, %	54	With phase change 13 Without phase change 17
Thermal cycle efficiency, %	85	62.7
Solar thermal conversion system weight-to-power ratio, kg/kW	2.17	2.61
Solar thermal conversion system surface power density, kW/m ²	12.3	6.79
Power plant solar thermal conversion system weight-to-power ratio kW/ kg	0.46	0.38

APPLIED SOLAR ENERGY Vol. 55 No. 6 2019

COMPARATIVE CHARACTERISTICS OF THE MASSES OF SPS AND GSPS OF THERMAL CONVERSION SYSTEM

Elements with a generator output of 1.1 GW	Weight, T	GSPS weight , T in 1.1 GW
Heat dissipation system	30960	-
Radiation receivers	9070	876-890
Recuperators and heat exchangers	4380	-
Electric generators	4320	993
Facets	4200	Concentrator 109
Design	2730	78
Turbochargers	1950	-
Generator cooling system	820	32
Total	58430	2102

At the present stage, the possibility of using ultra-strong and lightweight structural materials from carbon-carbon composites for the manufacture of the frame and load-bearing elements of the SPS has arisen. The use of high-temperature superconductors and superconducting electric generators created on their basis can significantly reduce the weight and size parameters of the superconducting SPS of the thermal conversion system.

SOLUTION OF THE TRANSPORTATION PROBLEM OF LEAVING TO THE LAND-ORBIT GPS

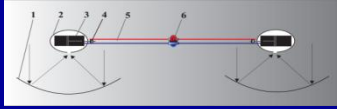

1, 2 - film-type concentrator and heat trap with elastic elements for deployment from the transport position; 3 - heat-receiving module; 4 - motion transducer; 5 - load-bearing power truss; 6 - electric generator.

The developed method of placing GPS parts in the useful volume of a launch vehicle with a diameter of 6.36 m and a height of 13 m allows it to be deployed in orbit into an operational state with the following parameters: diametric distance between modules $L = 70$ m, outer diameter of a circular parabolic-cylindrical concentrator $D = 120$ m, inner diameter parabolic-cylindrical concentrator, where there is no reception of solar radiation $d = 10$ m, losses in heat-emitting zones "windows" $W = 3.2$ MW, power consumption of solar radiation by a heat-converting system $W = 11.74$ MW.

Thanks for reading